



Low power Multimedia Bluetooth™ Module with antenna F2M03MLA Datasheet

Features

- Fully qualified end product with Bluetooth™ v2.0, CE and FCC
- Low power consumption
- Integrated high output antenna
- Transmit power up to +8dBm
- Class1/ 2/ 3 Configurable
- Range up to 150m (line of sight)
- Piconet and Scatternet capability, support for up to 7 slaves
- Require only few external components
- Industrial temperature range -40°C to +85°C
- Serial interface up to 1.5Mbps
- Extensive digital and analog I/O interface
- 16-bit Stereo codec
- 32-bit Kalimba DSP for enhanced audio applications and other general purpose applications
- Many digital audio options: PCM, I²S and SPDIF
- Large internal memory for custom applications
- RoHS compliant



Applications

- Stereo headphones
- Automotive hands-free kits
- Echo cancellation
- High performance telephony headsets
- Industrial and domestic appliances
- Medical systems
- Automotive applications
- Stand-alone sensors
- Embedded systems
- Cordless headsets
- Handheld, laptop and desktop computers
- Mobile phones

General Description

F2M03MLA is a low power embedded Bluetooth™ v2.0 multimedia module with an on board antenna, integrated stereo amplifier and a 32 bit digital signal processor (DSP) allowing enhanced audio algorithms such as MP3 decoding and advanced echo cancellation as well as other general purpose applications. The module is a fully Bluetooth™ compliant device for audio and data communication. With a transmit power of up to +8 dBm and receiver sensibility of down to -81dBm combined with stereo sound and low power consumption the F2M03MLA is suitable for the most demanding audio applications. The module is fully Bluetooth™ v2.0 qualified and it is certified according to CE and FCC, which give fast and easy Plug-and-Go implementation and short time to market.

F2M03MLA has by default the very easy-to-use Wireless Audio Headset firmware consisting of five Bluetooth profiles: Stereo Headset, HandsFree, A2DP, AVRCP and SPP profile. The module can optionally be delivered with customized firmwares.



BLUETOOTH is a trademark owned by Bluetooth SIG, Inc., U.S.A. and licensed to Free2move

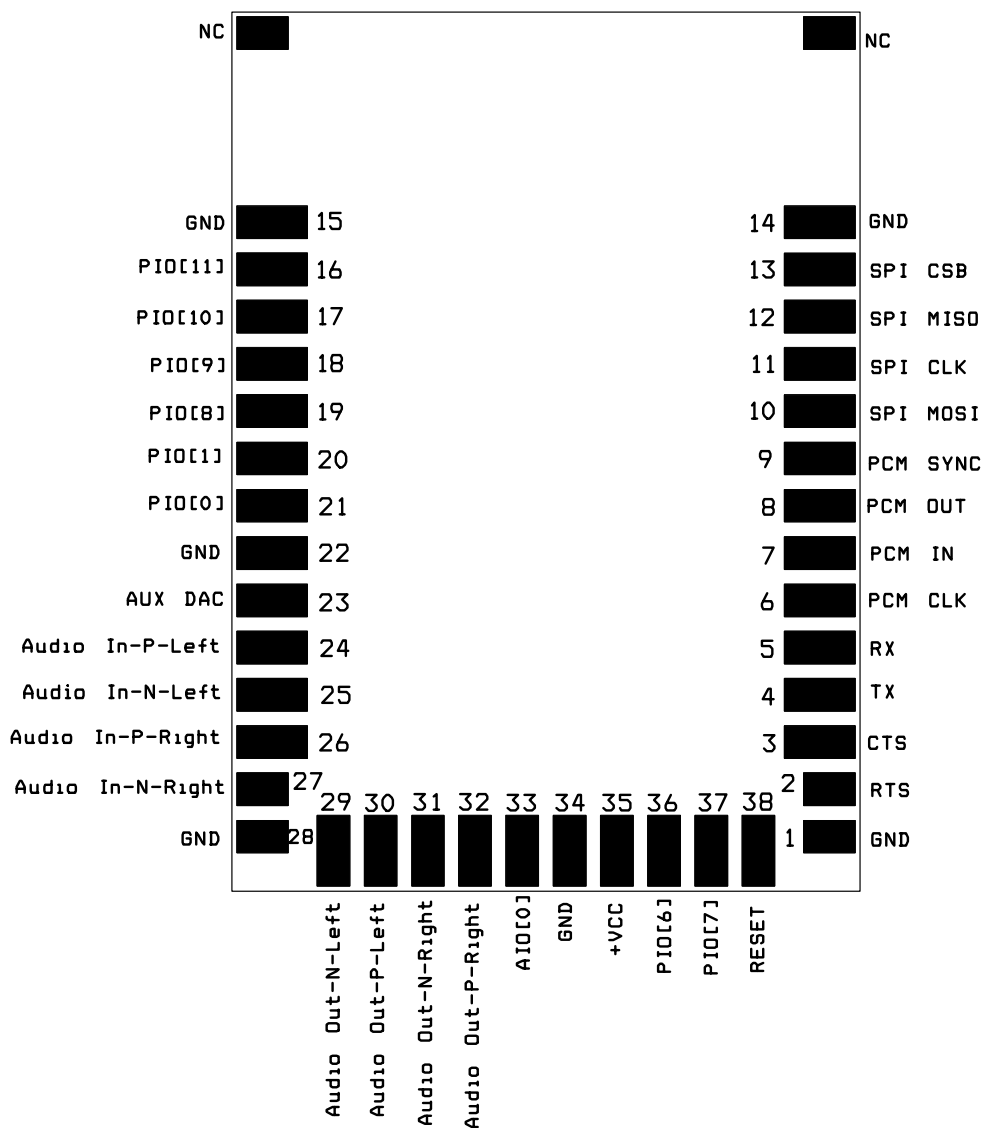

Table of contents

1	Device pinout	3
2	Device terminal functions	4
3	Electrical Characteristics	5
4	Radio Characteristics	9
5	Firmware versions	10
5.1	Wireless Audio	11
5.2	Customised firmwares	12
6	Device terminal description	13
6.1	Stereo Audio Interface	13
6.2	PCM CODEC Interface	16
6.3	UART Interface	31
6.4	Serial Peripheral Interface	33
6.5	I ² C Interface	33
6.6	PIOs	34
6.7	Power supply	35
7	Application information	36
7.1	Recommended land pattern.....	36
7.2	Layout guidelines	37
7.3	Typical application schematic	38
8	Package information	40
9	Certifications	41
9.1	Bluetooth	41
9.2	CE	41
9.3	FCC.....	42
10	RoHS and WEEE Statement	43
11	Tape and Reel information	44
11.1	Package Tape dimensions.....	44
11.2	Reel dimensions	44
12	Ordering information	45
13	Document history	46
14	Acronyms and definitions	47



1 Device pinout



Pinout of the F2M03MLA seen from the component side [TOP VIEW]



Low power Multimedia Bluetooth™ Module with antenna F2M03MLA Datasheet

2 Device terminal functions

Ground	Pin	Pin type	Description
GND	1,14,15,22,28,34	VSS	Ground connections
Power supplies	Pin	Pin type	Description
+VCC	35	VDD	Positive voltage supply (3.0-3.6)
Analog I/O	Pin	Pin type	Description
AIO[0]	33	Bi-directional	Programmable input/output line also possible to use as digital I/O
AUX DAC	23	Analogue output	Voltage DAC output
Reset	Pin	Pin type	Description
RESET	38	CMOS input with internal pull-up (10kΩ)	Reset if low. Input debounced so must be low for >5ms to cause a reset
Test and debug	Pin	Pin type	Description
SPI MISO	12	CMOS output, tristatable with weak internal pull-down	Serial Peripheral Interface data output
SPI CSB	13	CMOS input with weak internal pull-up	Chip select for Synchronous Serial Interface, active low
SPI CLK	11	CMOS input with weak internal pull-down	Serial Peripheral Interface clock
SPI MOSI	10	CMOS input with weak internal pull-down	Serial Peripheral Interface data input
UART	Pin	Pin type	Description
CTS	3	CMOS input with weak internal pull-down	UART clear to send active low
TX	4	CMOS output	UART data output active high
RTS	2	CMOS output, tristatable with internal pull-up	UART request to send active low
RX	5	CMOS input with weak internal pull-down	UART data input active high
PCM	Pin	Pin type	Description
PCM_OUT / SPDIF_OUT / SD_OUT	8	CMOS output, tristatable with internal weak pull down	Synchronous data output
PCM_SYNC / WS	9	Bi-directional with weak internal pull-down	Synchronous data SYNC
PCM_IN / SPDIF_IN / SD_IN	7	CMOS input, with weak internal pull-down	Synchronous data input
PCM_CLK / SCK	6	Bi-directional with weak internal pull-down	Synchronous data clock
AUDIO	Pin	Pin type	Description
In-P-Left	24	Analogue input	Microphone input positive (left side)
In-N-Left	25	Analogue input	Microphone input negative (left side)
In-P-Right	26	Analogue input	Microphone input positive (right side)
In-N-Right	27	Analogue input	Microphone input negative (right side)
Out-N-Left	29	Analogue output	Speaker output negative (left side)
Out-P-Left	30	Analogue output	Speaker output positive (left side)
Out-N-Right	31	Analogue output	Speaker output negative (right side)
Out-P-Right	32	Analogue output	Speaker output positive (right side)
PIO	Pin	Pin type	Description
PIO[11]	16	Bi-directional with programmable strength internal pull-up/down	Programmable input/output line
PIO[10]	17	Bi-directional with programmable strength internal pull-up/down	Programmable input/output line
PIO[9]	18	Bi-directional with programmable strength internal pull-up/down	Programmable input/output line
PIO[8]	19	Bi-directional with programmable strength internal pull-up/down	Programmable input/output line
PIO[7]	37	Bi-directional with programmable strength internal pull-up/down	Programmable input/output line
PIO[6]	36	Bi-directional with programmable strength internal pull-up/down	Programmable input/output line
PIO[1]	20	Bi-directional with programmable strength internal pull-up/down	Programmable input/output line
PIO[0]	21	Bi-directional with programmable strength internal pull-up/down	Programmable input/output line or Optionally WLAN_Active/Ch_Data input for co-existence signalling
Not connected	Pin	Pin type	Description
NC		Not connected	Soldering pads for stability



3 Electrical Characteristics

Absolute Maximum Ratings

Rating	Min	Max
Storage Temperature	-40°C	+85°C
Breakdown supply voltage	-0.4V	5.60V

Recommended Operating Conditions*

Rating	Min	Max
Operating temperature range	-40°C	+85°C
Supply voltage	3.1V	3.6V

*F2M03MLA meet the Bluetooth v2.0 specification when used in the recommended operating condition.

Digital Terminals

Digital Terminals	Min	Typ	Max	Unit
Input Voltage				
V _{IL} input logic level low, 2.7V ≤ VDD ≤ 3.0V	-0.4	-	+0.8	V
V _{IH} input logic level high	0.7VDD	-	VDD+0.4	V
Output Voltage				
V _{OL} output logic level low, (I _O = 4.0mA), 2.7V ≤ VDD ≤ 3.0V	-	-	0.2	V
V _{OH} output logic level high, (I _O = 4.0mA), 2.7V ≤ VDD ≤ 3.0V	VDD-0.2	-	-	V
Input and tristate current				
Strong pull-up	-100	-40	-10	μA
Strong pull-down	+10	+40	+100	μA
Weak pull-up	-5.0	-1.0	-0.2	μA
Weak pull-down	+0.2	+1.0	+5.0	μA
I/O pad leakage current	-1	0	+1	μA
C _I Input Capacitance	1.0	-	5.0	pF

Auxiliary ADC

Auxiliary ADC, 8-bit resolution	Min	Typ	Max	Unit
Resolution	-	-	8	Bits
Input voltage range (LSB size = 1.8/255= 7.1mV)	0	-	1.8	V
Accuracy (Guaranteed monotonic)	INL	-	1	LSB
	DNL	0	-	1
Offset	-1	-	1	LSB
Gain Error	-0.8	-	0.8	%
Input Bandwidth	-	100	-	KHz
Conversion time	-	2.5	-	μS
Sample rate*	-	-	700	Sample/s

*The ADC is accessed through the VM function. The sample rate given is achieved as a part of this function



Low power Multimedia Bluetooth™ Module with antenna F2M03MLA Datasheet

Auxiliary DAC

Auxiliary DAC, 8-bit resolution	Min	Typ	Max	Unit
Resolution	-	-	8	Bits
Average output step size	12.1	12.9	14.1	mV
Output Voltage	Monotonic			
Voltage range ($I_o=0mA$)	0	-	VDD	V
Current range	-10.0	-	+0.1	mA
Minimum output voltage ($I_o=100\mu A$)	0	-	0.2	V
Maximum output voltage ($I_o=10mA$)	VDD-0.3	-	VDD	V
High impedance leakage current	-1	-	+1	μA
Offset	-220	-	+120	MV
Integral non-linearity	-2	-	+2	LSB
Settling time (50pF load)	-	-	10	μS

Notes:

Current drawn into a pin is defined as positive; current supplied out of a pin is defined as negative.

Stereo Audio CODEC Characteristics

ADC

Parameter	Symbol	Conditions	Min	Typ	Max	Unit
Resolution	NOB		-	-	16	Bits
Input sample rate	F_{sample}		8	-	44.1	kHz
Signal to noise ratio + distortion ¹	SINAD	$0 \rightarrow \frac{1}{2}F_{sample}$, $f_{in}=1kHz$	-	84	-	dB
		$F_{sample}=8kHz$	-	83	-	dB
		$F_{sample}=11.025kHz$	-	84	-	dB
		$F_{sample}=16kHz$	-	83	-	dB
		$F_{sample}=22.050kHz$	-	80	-	dB
		$F_{sample}=32kHz$	-	74	-	dB
		$F_{sample}=44.1kHz$	-	-	-	dB
Digital gain			-24	-	21.5	dB

DAC

Parameter	Symbol	Conditions	Min	Typ	Max	Unit
Resolution	NOB		-	-	16	Bits
Output sample rate	F_{sample}		8	-	48	kHz
Gain resolution			-	3	-	dB
Signal to noise ratio + distortion ¹	SINAD	$0 \rightarrow 20kHz$, $f_{in}=1kHz$	-	79	-	dB
		$F_{sample}=8kHz$	-	78	-	dB
		$F_{sample}=11.025kHz$	-	79	-	dB
		$F_{sample}=16kHz$	-	88	-	dB
		$F_{sample}=22.050kHz$	-	90	-	dB
		$F_{sample}=32kHz$	-	90	-	dB
		$F_{sample}=44.1kHz$	-	89	-	dB
		$F_{sample}=48kHz$	-	-	-	dB
Digital gain			-24	-	21.5	dB

¹Measurements refer to digital part only

Audio Input, Microphone Amplifier

	Min	Typ	Max	Unit
Input full scale at maximum gain	-	4	-	mV rms
Input full scale at minimum gain	-	400	-	mV rms
Gain resolution	-	3	-	dB
Distortion at 1kHz	-	-	-74	dB
Input referenced rms noise	-	8	-	μV rms
3dB Bandwidth	-	17	-	kHz
Input impedance	-	20	-	k Ω
THD+N (microphone input) @ 30mV rms input	-	-66	-	dB
THD+N (line input) @ 300mV Ω input ²	-	-74	-	dB



Low power Multimedia Bluetooth™ Module with antenna F2M03MLA Datasheet

Audio Output, Speaker Output

Parameter	Symbol	Conditions	Min	Typ	Max	Unit
Allowed Load		Resistive	16	-	O.C	Ω
		Capacitive	-	-	500	pF
Max output voltage		$R_L=600\Omega$	-	2.0	-	V pk-pk
Max output current		$R_L=22\Omega$	-	75	-	mA
Total Harmonic Distortion plus Noise	THD+N	$f_{IN}=1\text{kHz}$, BW=22Hz to 22kHz $R_L=600\Omega$	-	0.015	-	%
Output noise relative to full scale	SNR	A Weighted, P_o =digital silence, $R_L=600\Omega$, BW=22Hz to 22kHz	-	-91	-	dB
Channel Separation (Crosstalk)	CS	$f_{IN}=10\text{kHz}$, analogue output set to maximum gain	-	-	-60	dB
Power Supply Rejection Ratio	PSRR	$V_{\text{ripple}}=200\text{mV}_{\text{pk-pk}}$ sinewave, 10kHz at $V_{DD} 3.1\text{V} \leq V_{DD} \leq 3.6\text{V}$, analogue output set to maximum gain	-	TBD	-	dB
Second Harmonic Level		1kHz sinewave, 1dB below full scale 600 Ω	-	<-95	-	dB
Third Harmonic Level		1kHz sinewave, 1dB below full scale 600 Ω	-	-95	-	dB

²Input signal amplitudes are expressed as the differential voltages between the MIC_P and MIC_N terminals

Typical THD + N Relative to Full Scale

Full Scale Output, mV rms	600 Ω		22 Ω	
	%	dB	%	dB
10	0.180	-54.7	0.180	-54.7
14	0.120	-58.2	0.120	-58.2
20	0.090	-60.7	0.090	-60.7
28	0.060	-64.2	0.062	-63.9
40	0.046	-66.5	0.048	-66.1
57	0.032	-69.7	0.036	-68.6
80	0.025	-71.8	0.030	-70.2
113	0.018	-74.6	0.024	-72.1
160	0.015	-76.2	0.022	-72.9
226	0.015	-76.2	0.020	-73.7
320	0.015	-76.2	0.019	-74.2
453	0.015	-76.2	0.019	-74.2
640	0.014	-76.8	0.019	-74.2
905	0.014	-76.8	0.019	-74.2
1280	0.014	-76.8	0.022	-72.9
1810	0.014	-76.8		



Low power Multimedia Bluetooth™ Module with antenna F2M03MLA Datasheet

Power Consumption

Typical Average Current Consumption		
VDD=3.3V Temperature = +20°C Output Power = 0dBm		
Mode	Average	Unit
SCO connection HV3 (30ms interval Sniff Mode) (Slave)	21	mA
SCO connection HV3 (30ms interval Sniff Mode) (Master)	21	mA
SCO connection HV3 (No Sniff Mode) (Slave)	28	mA
SCO connection HV1 (Slave)	42	mA
SCO connection HV1 (Master)	42	mA
ACL data transfer 115.2kbps UART no traffic (Master)	5	mA
ACL data transfer 115.2kbps UART no traffic (Slave)	22	mA
ACL data transfer 720kbps UART (Master or Slave)	45	mA
ACL data transfer 720kbps USB (Master or Slave)	45	mA
ACL connection, Sniff Mode 40ms interval, 38.4kbps UART	3.2	mA
ACL connection, Sniff Mode 1.28s interval, 38.4kbps UART	0.45	mA
Parked Slave, 1.28s beacon interval, 38.4kbps UART	0.55	mA
Standby Mode (Connected to host, no RF activity)	47	µA
Reset (RESET high or RESETB low)	15	µA
DSP		
DSP core (including PM memory access)		
Minimum (NOP)	0.25	mA/MIPS
Maximum (MAC)	0.65	mA/MIPS
DSP memory access (DM1 or DM2)	0.15	mA/MIPS
CODEC		
Microphone inputs and ADC / channel	0.85	mA
DAC and loudspeaker driver, no signal / channel	1.4	mA
Digital audio processing subsystem	8	mA

Peak current consumption		
VDD=3.3V Temperature = +20°C Output Power (max)= 7dBm		
Mode	Typ	Unit
Peak consumption during RF peaks	75	mA



Low power Multimedia Bluetooth™ Module with antenna F2M03MLA Datasheet

4 Radio Characteristics

VDD = 3.3V Temperature = 20 °C Frequency = 2.441GHz
All measurements are based on the Bluetooth test specification.

Radio Characteristics	VDD = 3.3V			Temperature = +25°C	
	Min	Typ	Max	Bluetooth Specification	Unit
Operating frequency	2402	-	2480		MHz
Maximum RF transmit power	7.8	8.6	9.9	0 to 20	dBm
Sensitivity at 0.1% BER	Frequency (GHz)			≤-70	dBm
	2.402	-	-85		
	2.441	-	-86		
	2.480	-	-85		
RF power control range	-	24	-	≥16	dB
RF power range control resolution	2.2	4	4.4	-	dB
20dB bandwidth for modulated carrier	-	800	-	≤1000	kHz
Δf1avg .Maximum Modulation.	-	165	-	40<f1avg<175	
Δf2max .Minimum Modulation.	-	150	-	115	
Δf1avg/Δf2avg	-	0.98	-	≥0.80	-
Initial carrier frequency tolerance	-	10	-	±75	kHz
Drift Rate	-	8	-	≤20	KHz/50μs
Drift (single slot packet)	-	7	-	≤25	kHz
Drift (five slot packet)	-	8	-	≤40	kHz

Note:

The F2M03MLA has a maximum transmit power of +8dBm and is certified according to the Bluetooth v2.0 specification as a Class1 device. It is though possible to restrict the maximum transmit power to comply with either a Class2 or Class3 device upon configuration.

Bluetooth Specification

Class of device	Maximum transmit power
Class1	+20dBm
Class2	+4dBm
Class3	0dBm



5 Firmware versions

F2M03MLA is supplied with Bluetooth stack firmware, which runs on the internal RISC micro controller of the Bluetooth module. This chapter includes an overview of the different options for more in depth information please use separate firmware datasheets provided by Free2move.

All firmware versions are compliant with the Bluetooth specification v2.0. The F2M03MLA software architecture allows Bluetooth processing to be shared between the internal microcontroller and a host processor. Depending on application the upper layers of the Bluetooth stack (above HCI) can execute on-chip or on the host processor.

Running the upper stack on the F2M03MLA module reduces (or eliminates, in the case of a on module application) the need for host-side software and processing time.

The integration approach depends on the type of product being developed. For example, performance will depend on the integration approach adopted. Free2move is currently offering two categories of Bluetooth stack firmware for the F2M03MLA:

- Wireless Audio Headset (WAH) is Free2move's standard firmware for Headset applications. It is intended for applications that want to incorporate Headset functionality to be able to communicate with for example mobile phones. The firmware can be used either as stand-alone with a button interface as the only input to control the firmware or connected to another serial device (e.g. microcontroller) through the UART interface.
- Customised firmwares. Free2move have the possibility to customise firmwares for special customer applications.



5.1 Wireless Audio

Wireless Audio Headset (WAH) is Free2move's standard firmware for Headset applications. It is intended for applications that want to incorporate Headset functionality to be able to communicate with for example mobile phones. The firmware can be used either as stand-alone with a button interface as the only input to control the firmware or connected to another serial device (e.g. microcontroller) through the UART interface.

The current version (V. 2.00) includes the following Bluetooth profiles:

- A2DP (sink)
- AVRCP (controller)
- HFP 1.5 (headset)
- HSP (headset)
- SPP (slave)

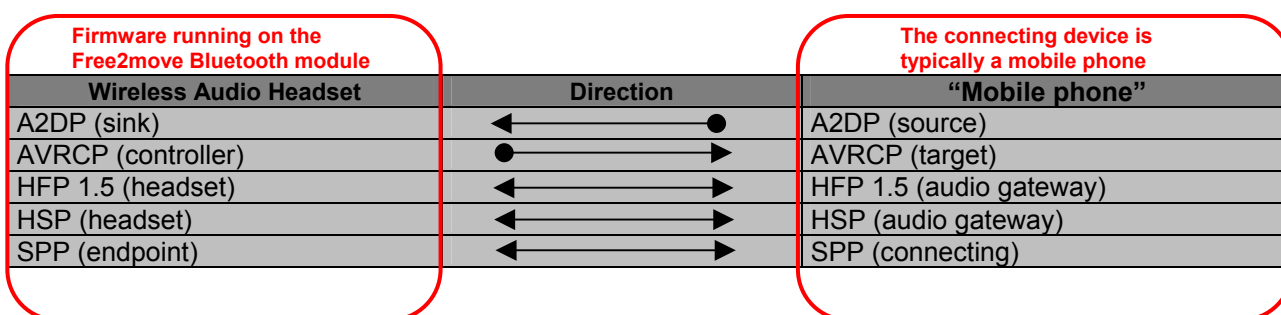

Please look at the full datasheet for the Wireless Audio Headset firmware for more information regarding the functionality.

5.1.1 Supported hardware

The Wireless Audio Headset V. 2.00 firmware is currently supported on the following Free2move products:

- F2M03MLA Free2move Low power Bluetooth Multimedia module with Antenna (Article nr. F2M03MLA-S03)



5.2 Customised firmwares

Customised firmwares can be made upon request. Free2move have the possibility to produce modules with customer specific settings of the Wireless Audio Headset firmware (most applicable in large production volumes).

Free2move can also provide special firmwares for customer applications.

Please consult your reseller for more information about customised firmwares and special requirements.

6 Device terminal description

6.1 Stereo Audio Interface

The main features of the interface are:

- Stereo and mono analogue input for voice band and audio band
- Stereo and mono analogue output for voice band and audio band
- Support for stereo digital audio bus standards such as I²S
- Support for IEC-60958 standard stereo digital audio bus standards i.e. S/PDIF and AES3/EBU
- Support for PCM interfaces including PCM master CODECs that require an external system clock

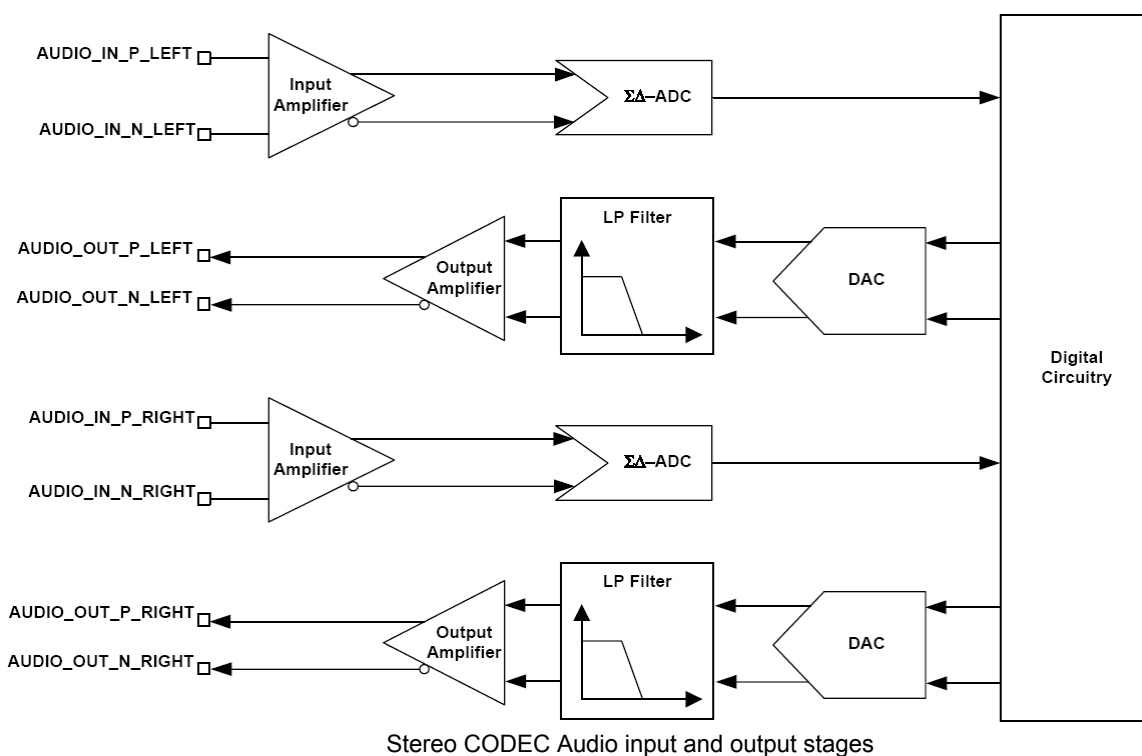

The stereo audio CODEC uses a fully differential architecture in the analogue signal path, which results in low noise sensitivity and good power supply rejection while effectively doubling the signal amplitude.

Important Note:

To avoid any confusion with respect to stereo operation this datasheet with respect to hardware explicitly states which is the left and right channel for audio input and output.

For mono operation F2M03MLA uses the left channel for standard mono operation for audio input and output.



6.1.1 ADC

The ADC consists of two second order Sigma Delta converters allowing two separate channels that are identical in functionality.

ADC Sample Rates

Each ADC supports the following sample rates:

- 8kHz
- 11.025kHz
- 16kHz
- 22.05kHz
- 24kHz
- 32kHz
- 44.1kHz

ADC Gain

The ADC contains two gain stages for each channel, an analogue and a digital gain stage. The digital gain stage has a range of -24dB to $+21.5\text{dB}$.

The ADC analogue amplifier is a two stage amplifier. The first stage of the analogue amplifier is responsible for selecting the correct gain for either microphone input or line input and therefore has two gain settings, one for the microphone and one for the line input. In simple terms the first stage amplifier has a selectable 20dB gain stage for the microphone and this creates the dual programmable gain required for the microphone or the line input. The equivalent block diagram for the two stage is shown in the figure below.

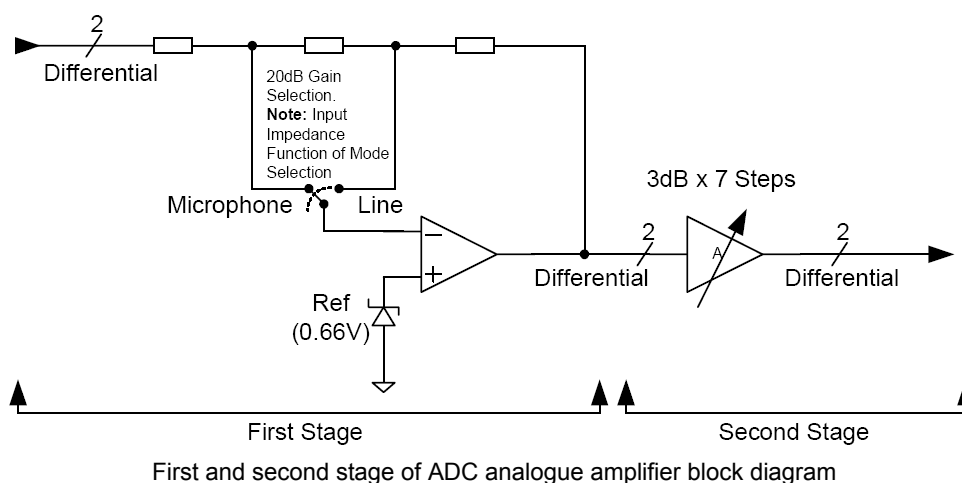

The second stage of the analogue amplifier has a programmable gain with seven individual 3dB steps. In simple terms, by combining the 20dB gain selection of the microphone input with the seven individual 3dB gain steps, the overall range of the analogue amplifier is approximately -4dB to 40dB . The overall gain setting of the ADC is a combined function of the digital and analogue amplifier settings, so that the fullscale range of the input to the ADC is kept to approximately 400mV rms.



6.1.2 DAC

The DAC consists of two second order Sigma Delta converters allowing two separate channels that are identical in functionality.

DAC Sample rates

Each DAC supports the following samples rates:

- 48kHz
- 44.1kHz
- 32kHz
- 24kHz
- 22.050kHz
- 16kHz
- 11.025kHz
- 8kHz

DAC Gain

The DAC contains two gain stages for each channel, a digital and an analogue gain stage. The digital gain stage has a programmable selection value in the range of -24dB to 21.5dB .

The DAC analogue amplifier unlike the ADC is a single stage amplifier with the same structure as the second stage of the ADC analogue amplifier. The structure of the DAC analogue amplifier is similar to the second stage of the ADC analogue amplifier.

The overall gain setting of the DAC is a combined function of the digital and analogue amplifier settings, therefore for a 1V rms nominal digital output signal from the digital gain stage of the DAC, the approximate output values of the analogue amplifier of the DAC is in the range of 0dB to -21dB .

6.1.3 Mono Operation

Mono operation is single channel operation of the stereo CODEC. The left channel represents the single mono channel for audio in and audio out. In mono operation the right channel is auxiliary mono channel that may be used in dual mono channel operation.



6.2 PCM CODEC Interface

Pulse Code Modulation (PCM) is the standard method used to digitise audio (particularly voice) for transmission over digital communication channels. Through its PCM interface, F2M03MLA has hardware support for continual transmission and reception of PCM data, thus reducing processor overhead for wireless headset and other audio applications. F2M03MLA offers a bi-directional digital audio interface that routes directly into the baseband layer of the on-chip firmware. It does not pass through the HCI protocol layer.

Hardware on F2M03MLA allows the data to be sent to and received from a SCO connection. Up to three SCO connections can be supported by the PCM interface at any one time⁽¹⁾

F2M03MLA can operate as the PCM interface Master generating an output clock of 128, 256 or 512kHz. When configured as PCM interface slave it can operate with an input clock up to 2048kHz. F2M03MLA is compatible with a variety of clock formats, including Long Frame Sync, Short Frame Sync and GCI timing environments.

It supports 13 or 16-bit linear, 8-bit μ -law or A-law companded sample formats at 8ksamples/s and can receive and transmit on any selection of three of the first four slots following PCM_SYNC. The PCM configuration options are enabled by firmware settings (contact Free2move).

F2M03MLA interfaces directly to PCM audio devices includes the following:

- WM8731 Audio CODEC from Wolfson Micro
- Qualcomm MSM 3000 series and MSM 5000 series CDMA baseband devices
- OKI MSM7705 four channel A-law and μ -law CODEC
- Motorola MC145481 8-bit A-law and μ -law CODEC
- Motorola MC145483 13-bit linear CODEC
- Winbond W681360R 13-bit linear CODEC
- STW 5093 and 5094 14-bit linear CODECs
- F2M03MLA is also compatible with the Motorola SSI™ interface

Note:

⁽¹⁾ Subject to firmware support, contact Free2move for current status.



6.2.1 PCM Interface Master/Slave

When configured as the Master of the PCM interface, F2M03MLA generates PCM_CLK and PCM_SYNC.

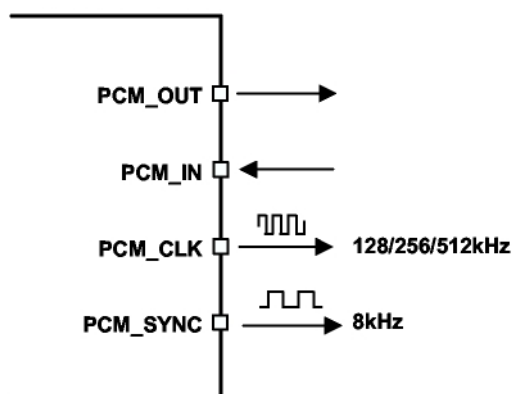

F2M03MLA as PCM Interface Master

When configured as the Slave of the PCM interface, F2M03MLA accepts PCM_CLK rates up to 2048kHz

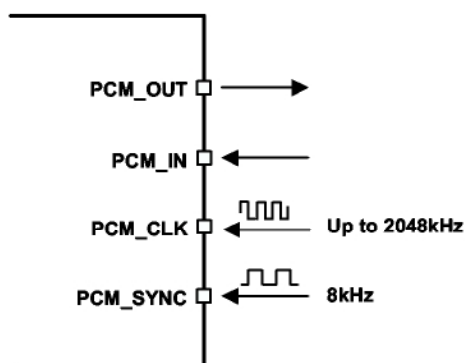

F2M03MLA as PCM Interface Master



6.2.2 Long Frame Sync

Long Frame Sync is the name given to a clocking format that controls the transfer of PCM data words or samples. In Long Frame Sync, the rising edge of PCM_SYNC indicates the start of the PCM word. When F2M03MLA is configured as PCM Master, generating PCM_SYNC and PCM_CLK, then PCM_SYNC is 8-bits long. When F2M03MLA is configured as PCM Slave, PCM_SYNC may be from two consecutive falling edges of PCM_CLK to half the PCM_SYNC rate (i.e., 62.5µs) long.

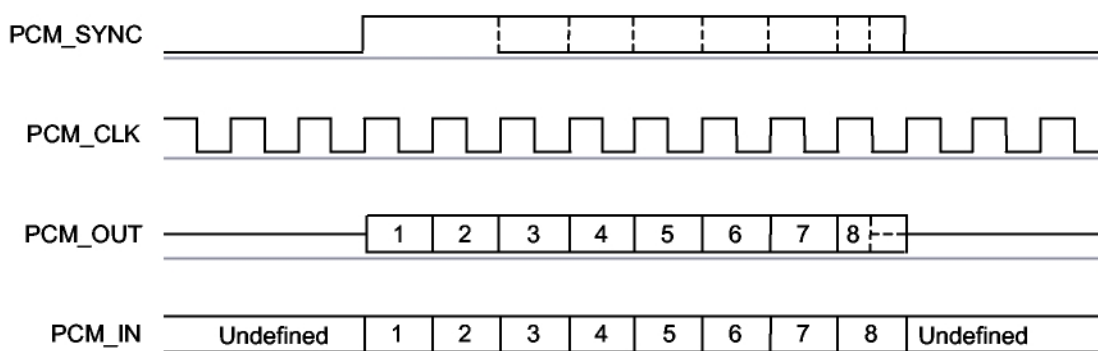

Long Frame Sync (Shown with 8-bit Companded Sample)

F2M03MLA samples PCM_IN on the falling edge of PCM_CLK and transmits PCM_OUT on the rising edge. PCM_OUT may be configured to be high impedance on the falling edge of PCM_CLK in the LSB position or on the rising edge.

6.2.3 Short Frame Sync

In Short Frame Sync the falling edge of PCM_SYNC indicates the start of the PCM word. PCM_SYNC is always one clock cycle long.

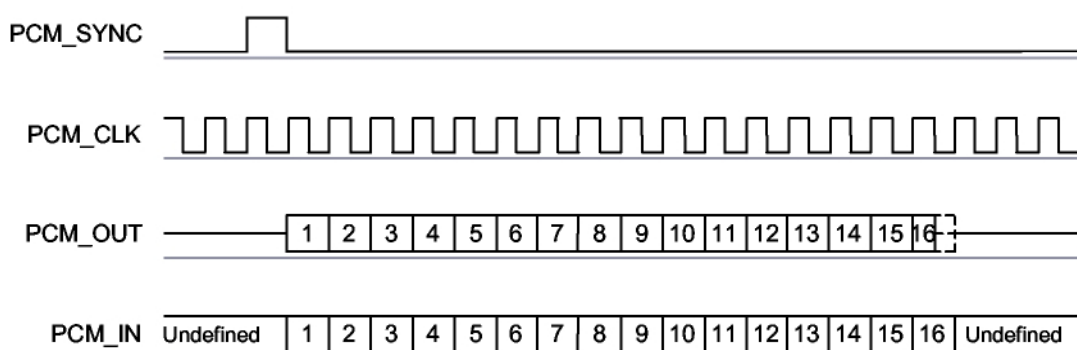

Short Frame Sync (Shown with 16-bit Sample)

As with Long Frame Sync, F2M03MLA samples PCM_IN on the falling edge of PCM_CLK and transmits PCM_OUT on the rising edge. PCM_OUT may be configured to be high impedance on the falling edge of PCM_CLK in the LSB position or on the rising edge.



6.2.4 Multi-Slot Operation

More than one SCO connection over the PCM interface is supported using multiple slots. Up to three SCO connections can be carried over any of the first four slots.

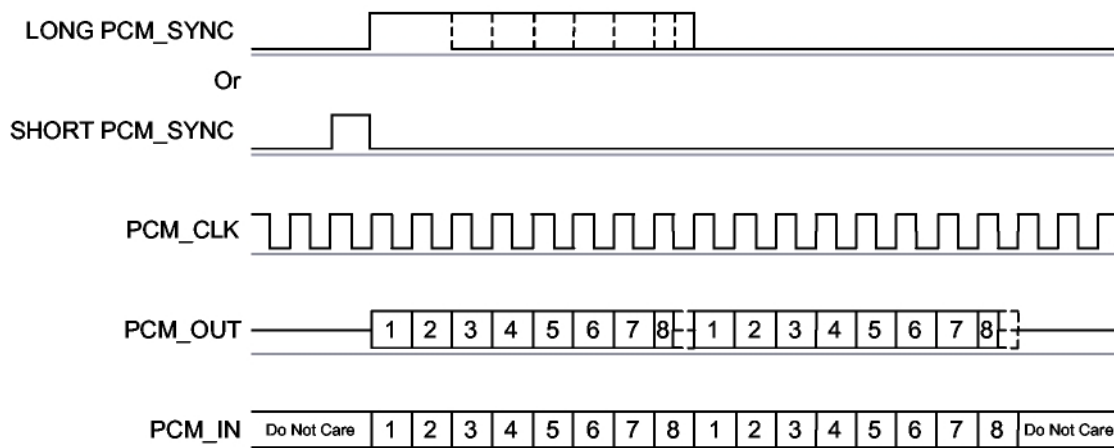

Multi-slot Operation with Two Slots and 8-bit Companded Samples

6.2.5 GCI Interface

F2M03MLA is compatible with the General Circuit Interface, a standard synchronous 2B+D ISDN timing interface. The two 64Kbps B channels can be accessed when this mode is configured. In the GCI interface two clock cycles are required for each bit of the voice sample. The voice sample format is 8-bit companded. As for the standard PCM interface up to 3 SCO connections can be carried over the first four slots.

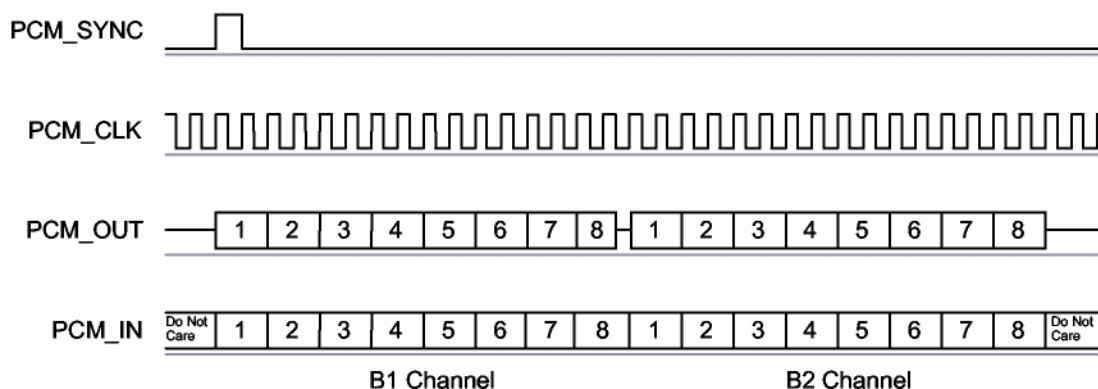

GCI Interface

The start of frame is indicated by PCM SYNC and runs at 8kHz. With F2M03MLA in Slave mode, the frequency of PCMCLK can be up to PCM_SYNC. In order to configure the PCM interface to work in GCI mode it is necessary to have the correct firmware support (contact Free2move)



6.2.6 Slots and Sample Formats

F2M03MLA can receive and transmit on any selection of the first four slots following each sync pulse. Slot durations can be either 8 or 16 clock cycles. Durations of 8 clock cycles may only be used with 8-bit sample formats. Durations of 16 clocks may be used with 8, 13 or 16-bit sample formats.

F2M03MLA supports 13-bit linear, 16-bit linear and 8-bit μ -law or A-law sample formats. The sample rate is 8ksamples/s. The bit order may be little or big endian. When 16-bit slots are used, the 3 or 8 unused bits in each slot may be filled with sign extension, padded with zeros or a programmable 3-bit audio attenuation compatible with some Motorola CODECs.

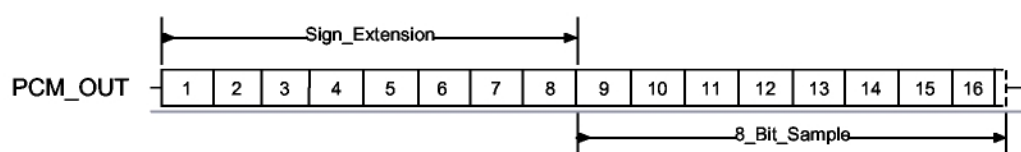

A 16-bit slot with 8-bit companded sample and sign extension selected

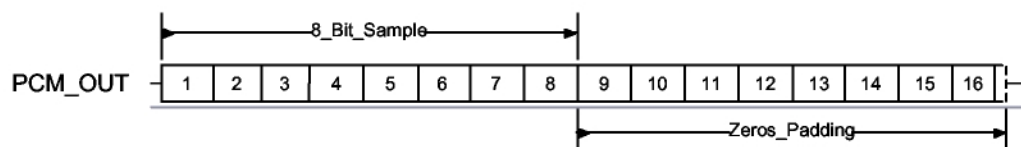

A 16-bit slot with 8-bit companded sample and zeros padding selected

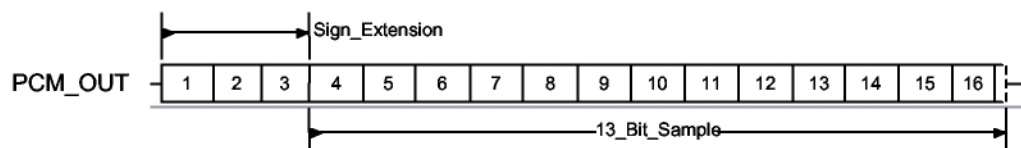

A 16-bit slot with 13-bit linear sample and sign extension selected

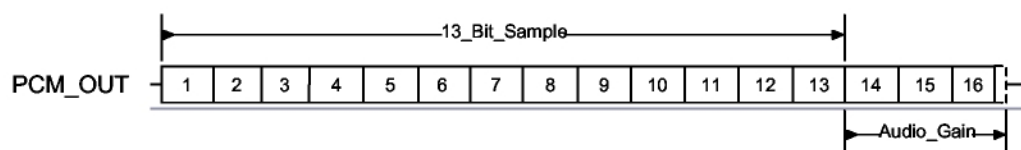

A 16-bit slot with 13-bit linear sample and audio gain selected

6.2.7 Additional Features

F2M03MLA has a mute facility that forces PCM_OUT to be 0. In Master mode, PCM_SYNC may also be forced to 0 while keeping PCM_CLK running (which some CODECS use to control power-down)



6.2.8 PCM Timing Information

PCM Master Timing

Symbol	Parameter		Min ⁽¹⁾	Typ	Max ⁽²⁾	Unit
f _{mclk}	PCM_CLK frequency	4MHz DDS generation	-	128 256 512	-	kHz
		48MHz DDS generation	2.9	-	-	kHz
-	PCM_SYNC frequency		-	8	-	kHz
t _{mclkh} ⁽¹⁾	PCM_CLK high	4MHz DDS generation	980	-	-	ns
t _{mclk} ⁽¹⁾	PCM_CLK low	4MHz DDS generation	730	-	-	ns
-	PCM_CLK jitter	48MHz DDS generation	-	-	21	Ns pk-pk
t _{dmclksynch}	Delay time from PCM_CLK high to PCM_SYNC high		-	-	20	ns
t _{dmclkpout}	Delay time from PCM_CLK high to valid PCM_OUT		-	-	20	ns
t _{dmclklsyncl}	Delay time from PCM_CLK low to PCM_SYNC low (Long Frame Sync only)		-	-	20	ns
t _{dmclksyncl}	Delay time from PCM_CLK high to PCM_SYNC low		-	-	20	ns
t _{dmclkpoutz}	Delay time from PCM_CLK low to PCMOUT high impedance		-	-	20	ns
t _{dmclkhoutz}	Delay time from PCM_CLK high to PCMOUT high impedance		-	-	20	ns
t _{supinclk}	Set-up time for PCM_IN valid to PCM_CLK low		30	-	-	ns
t _{hpinclk}	Hold time for PCM_CLK low to PCM_IN invalid		10	-	-	ns

Note:

⁽¹⁾ Assumes normal system clock operation. Figures will vary during low power modes, when system clock speeds are reduced.



Low power Multimedia Bluetooth™ Module with antenna F2M03MLA Datasheet

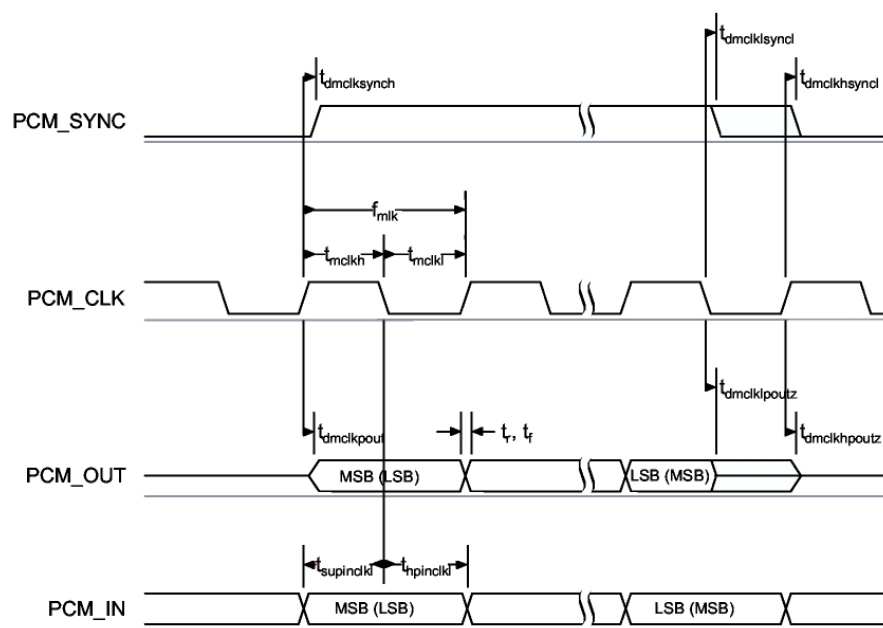

PCM Master Timing

PCM Slave Timing

Symbol	Parameter	Min	Typ	Max	Unit
f_{sclk}	PCM clock frequency (Slave mode: input)	64	-	2048	kHz
f_{sclk}	PCM clock frequency (GCI mode)	128	-	4096	kHz
t_{sckl}	PCM_CLK low time	200	-	-	ns
t_{sckh}	PCM_CLK high time	200	-	-	ns
$t_{hscklsynch}$	Hold time from PCM_CLK low to PCM_SYNC high	30	-	-	ns
$t_{suscklsynch}$	Set-up time for PCM_SYNC high to PCM_CLK low	30	-	-	ns
t_{dpout}	Delay time from PCM_SYNC or PCM_CLK whichever is later, to valid PCM_OUT data (Long Frame Sync only)	-	-	20	ns
$t_{dscklhpout}$	Delay time from CLK high to PCM_OUT valid data	-	-	20	ns
t_{dpoutz}	Delay time from PCM_SYNC or PCM_CLK low, whichever is later, to PCM_OUT data line high impedance	-	-	20	ns
$t_{supinsckl}$	Set-up time for PCM_IN valid to CLK low	30	-	-	ns
$t_{hpinsckl}$	Hold time for PCM_CLK low to PCM_IN invalid	30	-	-	ns
t_r	Edge rise time (CI = 50 pF, 10-90 %)	-	-	15	ns
T_f	Edge fall time (CI = 50 pF, 10-90 %)	-	-	15	ns



Low power Multimedia Bluetooth™ Module with antenna F2M03MLA
 Datasheet

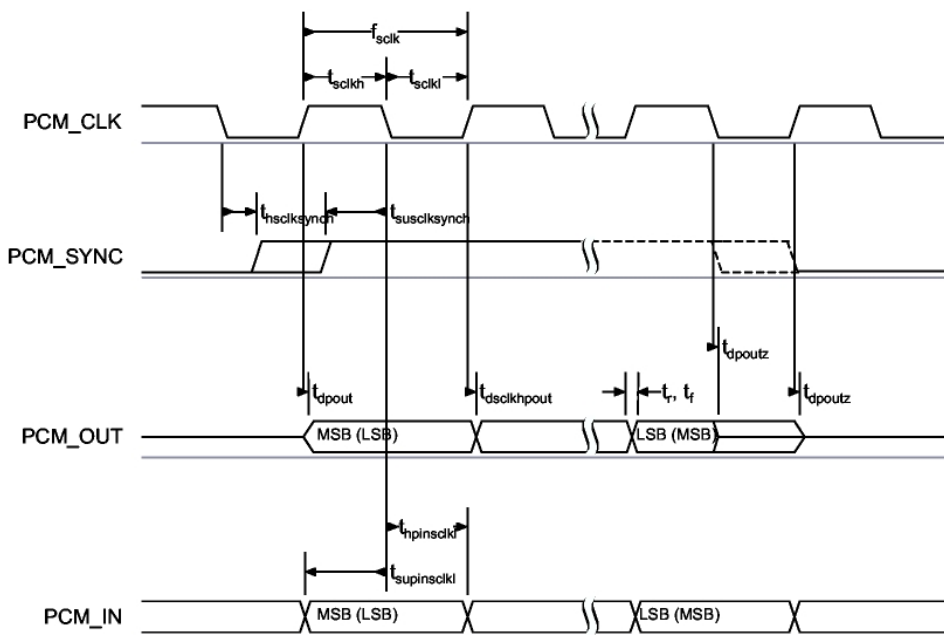

PCM slave timing



6.2.9 Digital Audio Bus

The digital audio interface supports the industry standard formats for I²S, left-justified (LJ) or right-justified(RJ)¹. The interface shares the same pins as the PCM interface and the timing diagram is shown in the figure below.

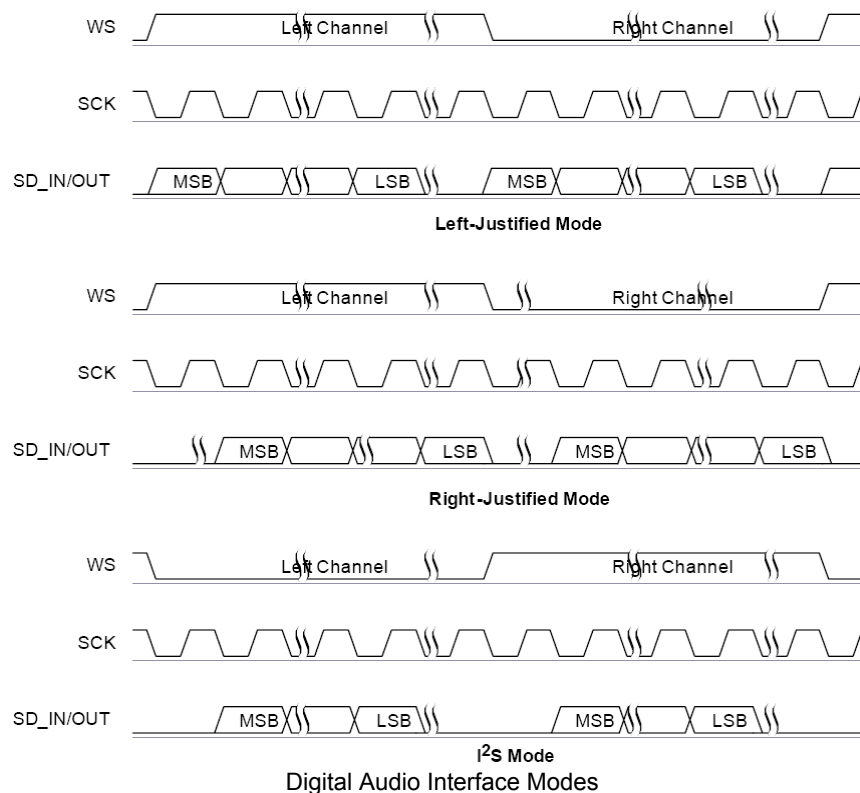

The internal representation of audio samples within F2M03MLA is 16-bit and data on SD_OUT is limited to 16-bit per channel. On SD_IN, if more than 16-bit per channel is present will round considering the 17th bit.

SCK typically operates 64 x WS frequency and cannot be less than 36 x WS.

Note:

¹ Subject to firmware support, contact Free2move for more information.

Digital Audio Interface Slave timing

Symbol	Parameter	Min	Typ	Max	Unit
-	SCK Frequency	-	-	6.2	MHz
-	WS Frequency	-	-	96	kHz
t_{ch}	SCK high time	-	-	-	ns
t_{cl}	SCK low time	-	-	-	ns
t_{opd}	SCK to SD_OUT delay	-	-	-	ns
t_{ssu}	WS to SCK high set-up time	-	-	-	ns
t_{sh}	WS to SCK high hold time	-	-	-	ns
t_{isu}	SD_IN to SCK high set-up time	-	-	-	ns
t_{ih}	SD_IN to SCK high hold time	-	-	-	ns

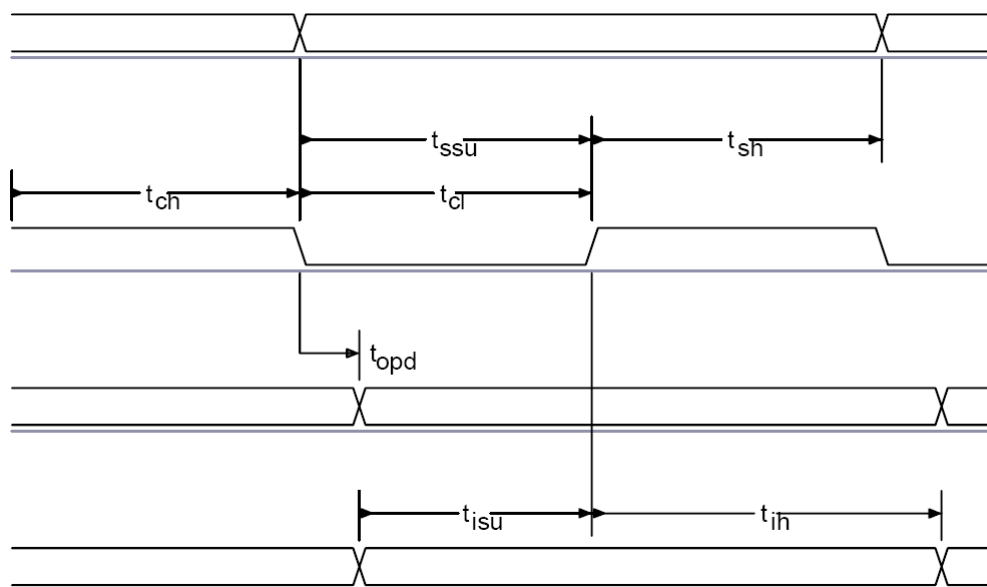

Digital Audio Interface Slave Timing

Digital Audio Interface Master timing

Symbol	Parameter	Min	Typ	Max	Unit
-	SCK Frequency	-	-	6.2	MHz
-	WS Frequency	-	-	96	kHz
t_{opd}	SCK to SD_OUT delay	-	-	-	ns
T_{spd}	SCK to WS delay	-	-	-	ns
t_{isu}	SD_IN to SCK high set-up time	-	-	-	ns
t_{ih}	SD_IN to SCK high hold time	-	-	-	ns

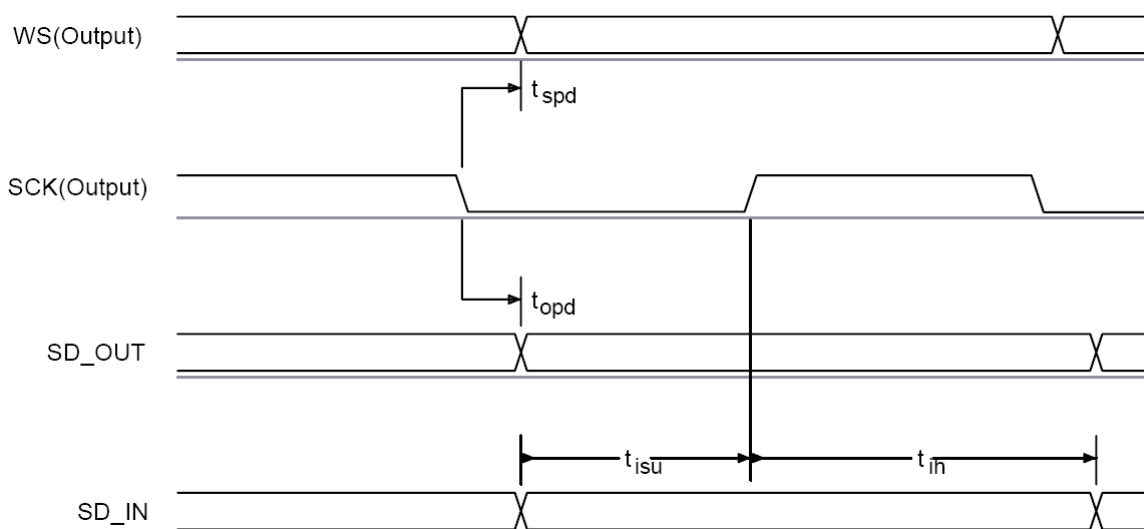

Digital Audio Interface Master Timing



6.2.10 IEC 60958 Interface

The IEC 60958 interface is a digital audio interface that uses bi-phase coding to minimise the DC content of the transmitted signal and allows the receiver to decode the clock information from the transmitted signal. The IEC 60958 specification is based on the two industry standards AES/EBU and the Sony and Philips interface specification SPDIF. The interface is compatible with IEC 60958-1, IEC 60958-3 and IEC 60958-4¹.

Note:

¹ Subject to firmware support, contact Free2move for information.

The SPDIF interface signals are SPDIF_IN and SPDIF_OUT and are shared on the PCM interface pins. The input and output stages of the SPDIF pins can interface either 75Ω coaxial cable with an RCA connector or there is an option to use an optical link that uses Toslink optical components. Typical output and input stage interfaces for the coaxial and alternative optical solution interface is shown in the figures below.

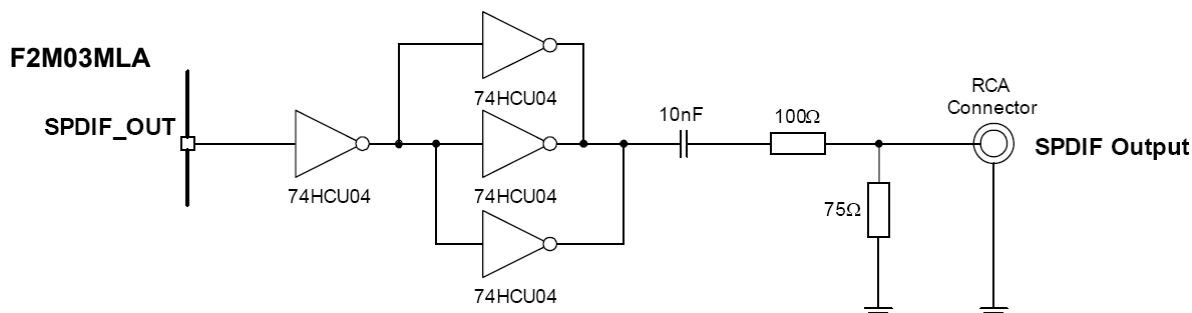

Example circuit for SPDIF Interface with coaxial output

Note: The 100Ω and 75Ω resistors are dependent on the supply voltage and therefore subject to change.

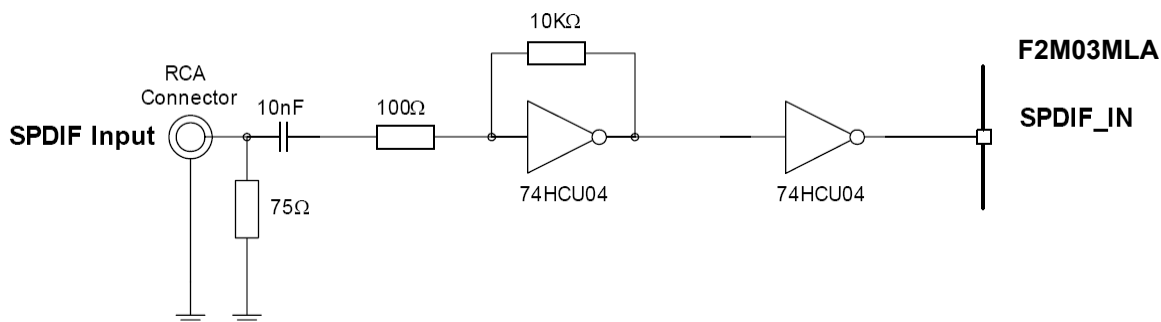

Example circuit for SPDIF Interface with coaxial input

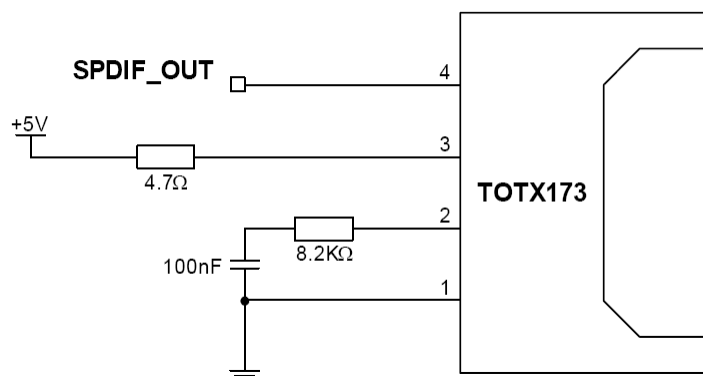

Example circuit for SPDIF interface with optical output

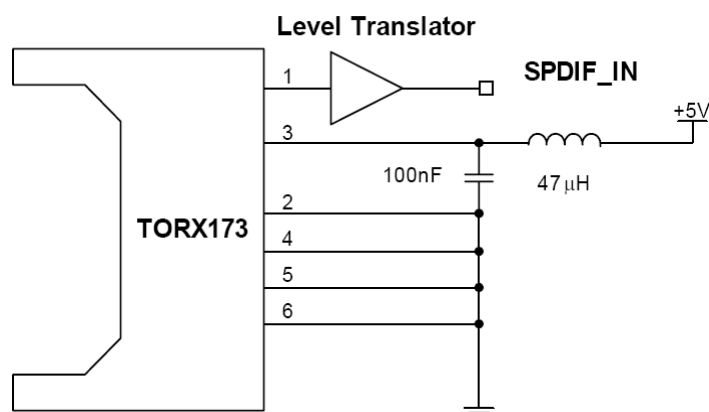

Example circuit for SPDIF interface with optical input

6.2.11 Audio Input Stage

The input stage of F2M03MLA consists of a low noise input amplifier, which receives its analogue input signal from pins AUDIO_IN_P_LEFT and AUDIO_IN_N_LEFT to a second-order Σ - Δ ADC that outputs a 4MBit/sec single-bit stream into the digital circuitry. The input can be configured to be either single ended or fully differential. It can be programmed for either microphone or line input and has a 3-bit digital gain setting of the input-amplifier in 3dB steps to optimize it for the use of different microphones.



6.2.12 Microphone Input

The audio-input is intended for use from $1\mu\text{V}@94\text{dB SPL}$ to about $10\mu\text{V}@94\text{dB SPL}$. With biasing-resistors R1 and R2 equal to $1\text{k}\Omega$, this requires microphones with sensitivity between about -40dBV/Pa and -60dBV/Pa . The microphone for each channel should be biased as shown in the figure below.

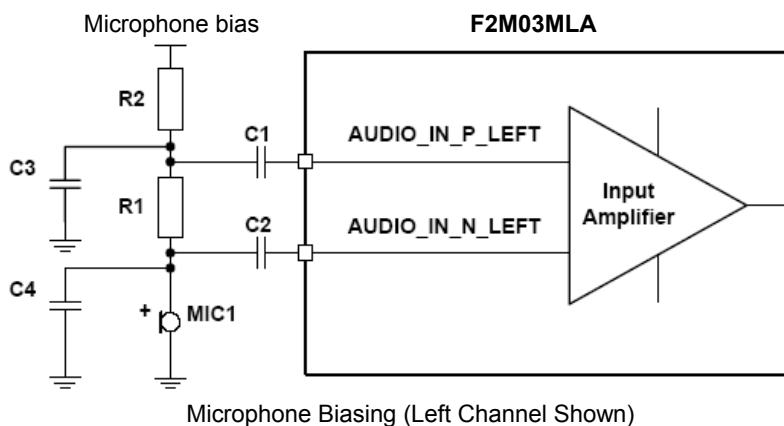

The input impedance at AUDIO_IN_N_LEFT, AUDIO_IN_P_LEFT, AUDIO_IN_N_RIGHT and AUDIO_IN_P_RIGHT is typically $20\text{k}\Omega$. C1 and C2 should be 47nF . R1 sets the microphone load impedance and is normally in a range of 1 to $2\text{k}\Omega$. R2, C3 and C4 improve the supply rejection by decoupling supply noise from the microphone. Values should be selected as required in the specification. R2 may be connected to a convenient supply (typically VDD).

6.2.13 Line Input

If the input gain is set to less than 21dB F2M03MLA automatically selects line input mode. In this mode the input impedance at AUDIO_IN_N_LEFT, AUDIO_IN_P_LEFT, AUDIO_IN_N_RIGHT and AUDIO_IN_P_RIGHT are increased to $130\text{k}\Omega$ typically. In line-input mode, the full-scale input signal is about 400mV rms . The figures below show two circuits for line input operation and show connections for either differential or single ended inputs.

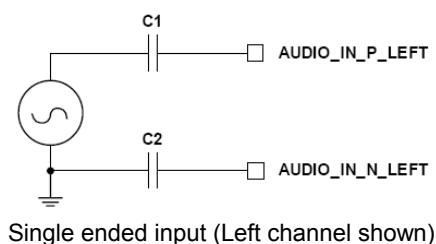
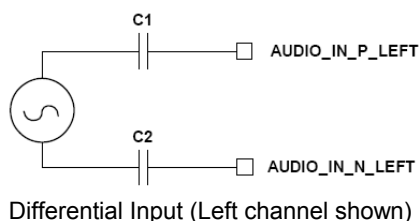



6.2.14 Output Stage

The output digital circuitry converts the signal from 16-bit per sample, linear PCM of variable sampling frequency to an 8 MBits/sec bit stream, which is fed into the analogue output circuitry.

The output circuit comprises a digital to analogue converter with gain setting and output amplifier. Its class-AB output-stage is capable of driving a signal on both channels of up to 2V pk-pk- differential into a load of 32 Ω and 500pF with a typical THD+N of -74dBc. The output is available as a differential signal between AUDIO_OUT_N_LEFT and AUDIO_OUT_P_LEFT for the left channel as shown in Figure 8.45; and between AUDIO_OUT_N_RIGHT and AUDIO_OUT_P_RIGHT for the right channel. The output is capable of driving a speaker directly if its impedance is at least 16 Ω if only one channel is connected or an external regulator is used.

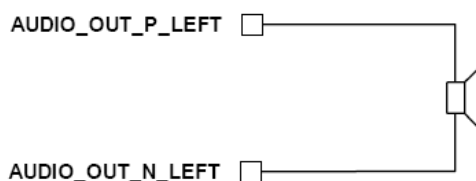

Speaker output (Left channel shown)

The gain of the output stage is controlled by a 3-bit programmable resistive divider, which sets the gain in steps of approximately 3dB.

The single bit stream from the digital circuitry is low pass filtered by a second order bi-quad filter with a pole at 20kHz. The signal is then amplified in the fully differential output stage, which has a gain bandwidth of typically 1MHz. It uses its high open loop gain in the closed loop application circuit to achieve low distortion while operating with low standing current.



6.3 UART Interface

The F2M03MLA Bluetooth module's Universal Asynchronous Receiver Transmitter (UART) interface provides a simple mechanism for communicating with other serial devices using the RS232 standard⁽¹⁾.

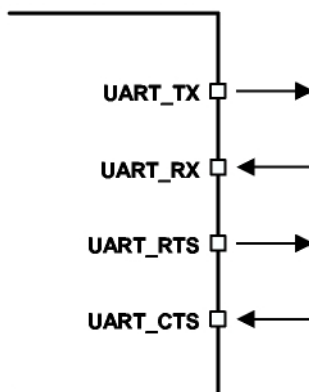

Universal Asynchronous Receiver

Four signals are used to implement the UART function, as shown in the figure above. When F2M03MLA is connected to another digital device, UART_RX and UART_TX transfer data between the two devices. The remaining two signals, UART_CTS and UART_RTS, can be used to implement RS232 hardware flow control where both are active low indicators. All UART connections are implemented using CMOS technology and have signalling levels of 0V and VDD. UART configuration parameters, such as Baud rate and packet format, are set by Free2move firmware.

Note:

In order to communicate with the UART at its maximum data rate using a standard PC, an accelerated serial port adapter card is required for the PC.

⁽¹⁾ Uses RS232 protocol but voltage levels are 0V to VDD, (requires external RS232 transceiver IC)

Parameter		Possible Values
Baud Rate	Minimum	1200 Baud ($\leq 2\%$ Error)
	Maximum	9600 Baud ($\leq 1\%$ Error)
Flow Control		RTS/CTS or None
Parity		None, Odd or Even
Number of Stop Bits		1 or 2
Bits per channel		8

Possible UART Settings



The UART interface is capable of resetting the Free2move module upon reception of a break signal. A Break is identified by a continuous logic low on the UART_RX terminal, as shown in figure below. If tBRK is longer than a special value, defined by the Free2move firmware a reset will occur. This feature allows a host to initialise the system to a known state. Also, the F2M03MLA can emit a Break character that may be used to wake the Host. The above capabilities are not supported in the standard firmware, please contact Free2move for more information.

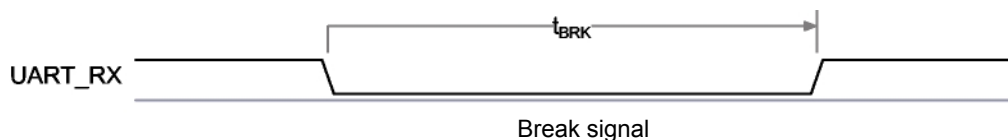



6.4 Serial Peripheral Interface

F2M03MLA is a slave device that uses terminals SPI_MOSI, SPI_MISO, SPI_CLK and SPI_CSB. This interface is used for program emulation/debug and IC test. It is also the means by which the F2M03MLA flash may be programmed, before any 'boot' program is loaded.

The SPI signals should be routed out from the module if you need to upgrade the firmware on the module in the future when the module is already soldered.

Note:

The designer should be aware that no security protection is built into the hardware or firmware associated with this port, so the terminals should not be permanently connected in a PC application. This interface is not a user interface and only used for initial download and configuration of the firmware for the module.

6.5 I²C Interface

PIO[8:6] can be used to form a master I2C interface. The interface is formed using software to drive these lines. Therefore, it is suited only to relatively slow functions such as driving a dot matrix liquid crystal display (LCD), keyboard scanner or EEPROM.

Notes:

The I²C interface is controlled by firmware specific settings. Please see specific firmware datasheet for information PIO lines need to be pulled-up through 2.2k resistors.

PIO[7:6] dual functions, UART bypass and EEPROM support, therefore, devices using an EEPROM cannot support UART bypass mode.

For connection to EEPROMs, contact Free2move for information about devices that are currently supported.

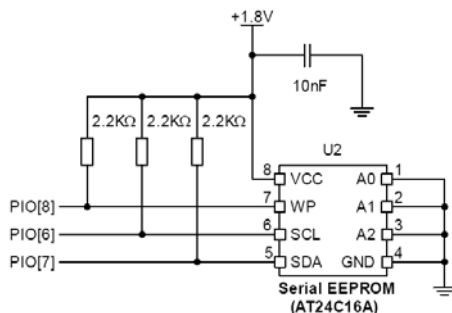

Example EEPROM Connection



6.6 PIOs

The F2M03MLA have 8 programmable general-purpose I/O ports PIO[11:6, 1:0] and one analog I/O port AIO[0]. The F2M03MLA also has one digital to analog port AUX_DAC. PIO lines can be configured through software to have either weak or strong pull-ups or pull-downs.

All PIO lines are configured as inputs with weak pull-downs at reset.

AIO[0] functions available via this pin include an 8-bit ADC but can also be used as general-purpose I/O line. Typically the AIO[0] is used for battery voltage measurement. The voltage range for AIO[0] is constrained by the internal analogue supply voltage which is 1.8V.

The AUX_DAC is a 8-bit Digital to Analog Converter used for customer specific applications. The voltage range is from 0V to VDD.

Note:

The PIO, AIO and AUX_DAC lines are controlled by firmware specific settings. Please see specific firmware datasheet for information about the PIOs used!

6.6.1 General-purpose I/O lines

PIO[0]

I/O terminal with programmable strength internal pull-up/down.

PIO[1]

I/O terminal with programmable strength internal pull-up/down.

PIO[6]

I/O terminal with programmable strength internal pull-up/down.

PIO[7]

I/O terminal with programmable strength internal pull-up/down.

PIO[8]

I/O terminal with programmable strength internal pull-up/down.

PIO[9]

I/O terminal with programmable strength internal pull-up/down.

PIO[10]

I/O terminal with programmable strength internal pull-up/down.

PIO[11]

I/O terminal with programmable strength internal pull-up/down.

6.6.2 Analog I/O lines

AIO[0]

Programmable input/output line also possible to use as digital I/O

AUX_DAC

Digital to Analog output line.



6.7 Power supply

The power supply for the F2M03MLA should be chosen carefully. Bad power supply can reduce the performance and may damage the module. Please use the recommended voltage regulator or consult Free2move if using another regulator. It is also essential to use a proper reset circuit to the module for correct operation.

6.7.1 Voltage regulator

The F2M03MLA has one power supply, +VCC.

The voltage supplied should have low noise, less than 10mV rms between 0 and 10MHz. The transient response of the regulator is also important. At the start of a Bluetooth packet, power consumption will jump to high levels. The regulator should have a response time of 20µs or less; it is essential that the power rail recovers quickly.

Recommended voltage regulator:

XC6209B332MR from Torex or TPS73633DBVTG4 from Texas Instrument

6.7.2 Reset

The F2M03MLA has an active low reset (pin nr: 38). The reset pin **MUST** be connected to either a reset-circuit (voltage monitor) such as the TC1270ASVRCTR, MAX811S, DS1818 or using an I/O from a microcontroller. Reset cannot be done with a R-C network. It is recommended to use one of the reset circuits mentioned above. Special considerations must be taken when using an I/O from a microcontroller; a pull-down resistor (typically 1.8kΩ) must be placed on the I/O-line.

It is recommended that RESET is applied for a period greater than 5ms.

At reset the digital I/O pins are set to inputs for bi-directional pins and outputs are tristated. The PIOs have weak pull-downs.



7 Application information

7.1 Recommended land pattern

All dimensions are in [mm]

F2M03MLA

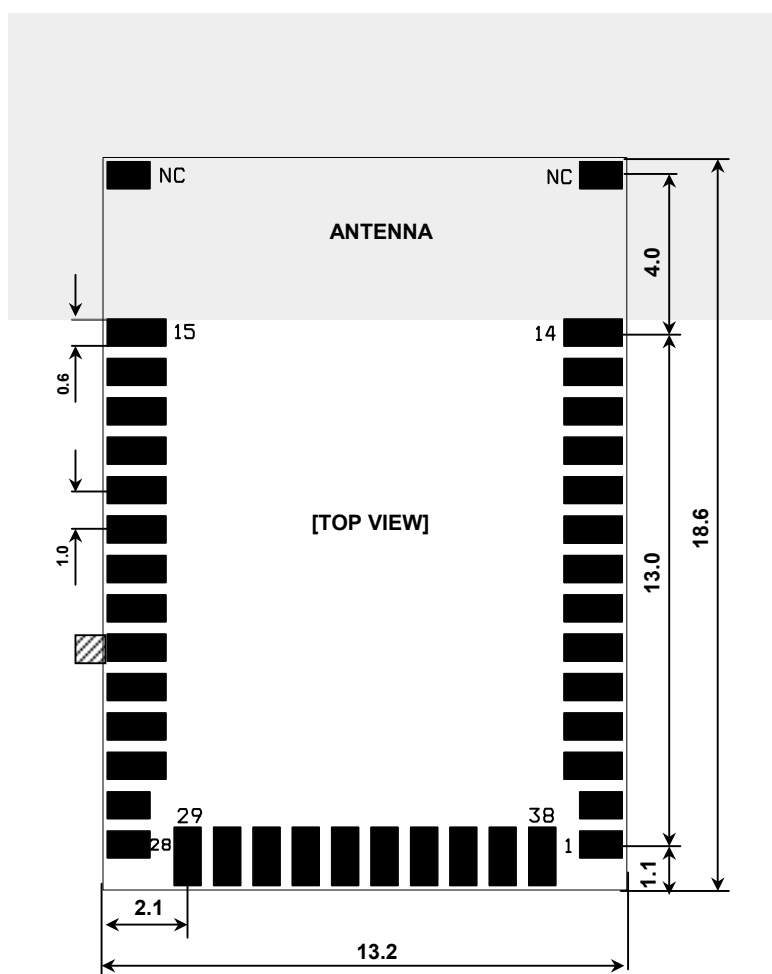

- Solder pad
- ▨ Recommended extended pad for manual soldering (apply for all solder pads)
- Restricted area for ground planes or other components

- Pad size: 0.6x1.4 and 0.6x0.8mm,
- Solder mask opening: Pad size + 0.1mm
- Pitch: 1.0mm



7.2 Layout guidelines

The module uses bottom pads for soldering optimized for an automatic solder line. It is also possible to solder the module manually by using hot air soldering. For manual soldering solder pads may in some situation be made slightly larger to allow easier heating process.

To achieve good RF performance it is recommended to place ground plane(s) beneath the module but not under the antenna. The ground planes should be connected with vias surrounding the module. Except from the ground plane it is preferable that there are as few components and other material as possible nearby the antenna. Free air is the best surrounding for the antenna.

All GND pads must be connected directly to a flooded ground-plane. If more then one ground layer is used then make a good connection between them using many via holes. +VCC should be connected to the voltage regulator using a wide trace.

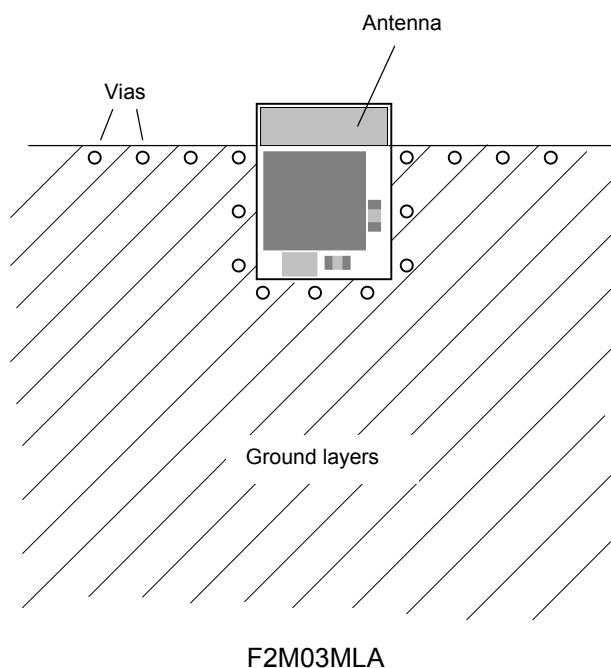



7.3 Typical application schematic



Low power Multimedia Bluetooth™ Module with antenna F2M03MLA Datasheet

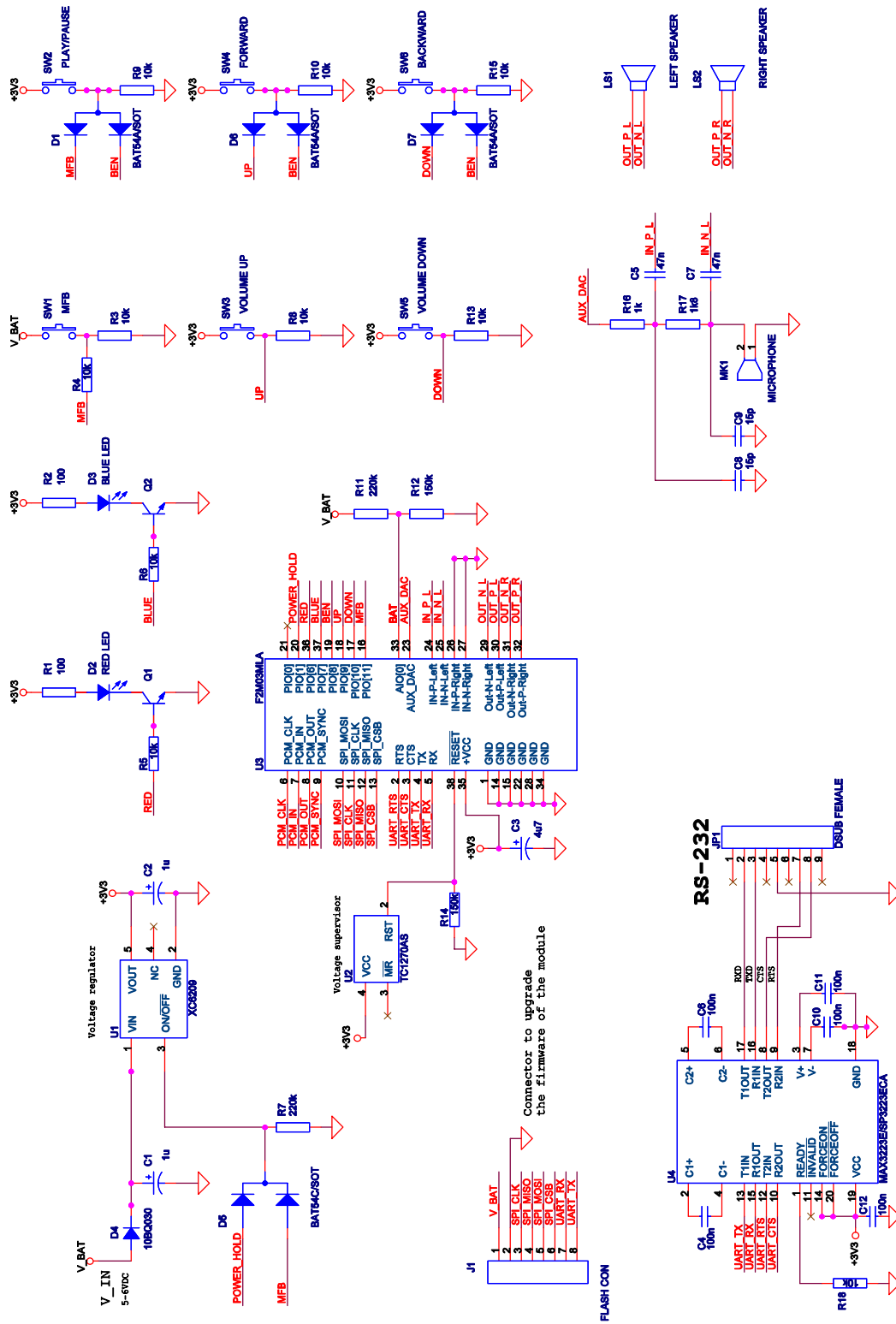



8 Package information

F2M03MLA

Physical size [mm]:

Length: 18.6

Width: 13.2

Height: 2.1

Weight: 1.2g



9 Certifications

9.1 Bluetooth

F2M03MLA has passed the Bluetooth Qualification/Certification process as specified within the Bluetooth Specifications and as required within the PRD 2.0.

QDID: B012539

9.2 CE

F2M03MLA complies with the requirements of R&TTE Directive 1999/5/CE, the European Community Directive 73/23/EEC and 93/68/EEC.

- EN 300 328
- EN 301 489-1/-17
- EN 60950



9.3 FCC

FCC-B Radio Frequency Interference Statement

This device has been tested and found to comply with the limits for a Class-B digital device, pursuant to part 15 of the FCC rules. These limits are designed to provide reasonable protection against harmful interference when the equipment is operated in commercial environment. This equipment generates, uses and can radiate radio frequency energy and, if not installed and used according with the instruction manual, may cause harmful interference to radio communication. Operation of this equipment in a residential area is likely to cause harmful interference, in which case the user will be required to correct the interference at his own expense.

Notice1

The changes or modifications not expressly approved by the party responsible for the compliance could void the user's authority to operate the equipment.

Notice 2

Shielded interface cables and A.C. power cord, if any, must be used in order to comply with the emission limits.

Notice 3

This modular transmitter uses an electronic display of the FCC identification number, the information must be readily accessible on the device in which it is installed.

The FCC ID can be read from the UART of the device.

UART Settings:

Baud rate: 38400bps

Data bits: 8

Parity: None

Stop bits: 1

Send command: "VERSION" (ASCII characters) over the UART and the module will respond with software, hardware information and the FCC ID.

FCC ID R47F2M03MLA

This device complies with part 15 of the FCC Rules. Operation is subject to the following two conditions: (1) This device may not cause harmful interference, and (2) This device must accept any interference received, including interference that may cause undesired operation.

If the module is installed inside another device, then the outside of the device into which the module is installed must display a label referring to the enclosed module. This exterior label can use wording such as the following: "Contains FCC certified transmitter module(s)."

Any similar wording that expresses the same meaning may be used.



10 RoHS and WEEE Statement

F2M03MLA meets the requirements of Directive 2002/95/EC of the European Parliament and of the Council on the Restriction of Hazardous Substance (RoHS).

F2M03MLA also meet the requirements of Directive 2002/96/EG -Waste Electrical and Electronic Equipment (WEEE).



11 Tape and Reel information

11.1 Package Tape dimensions

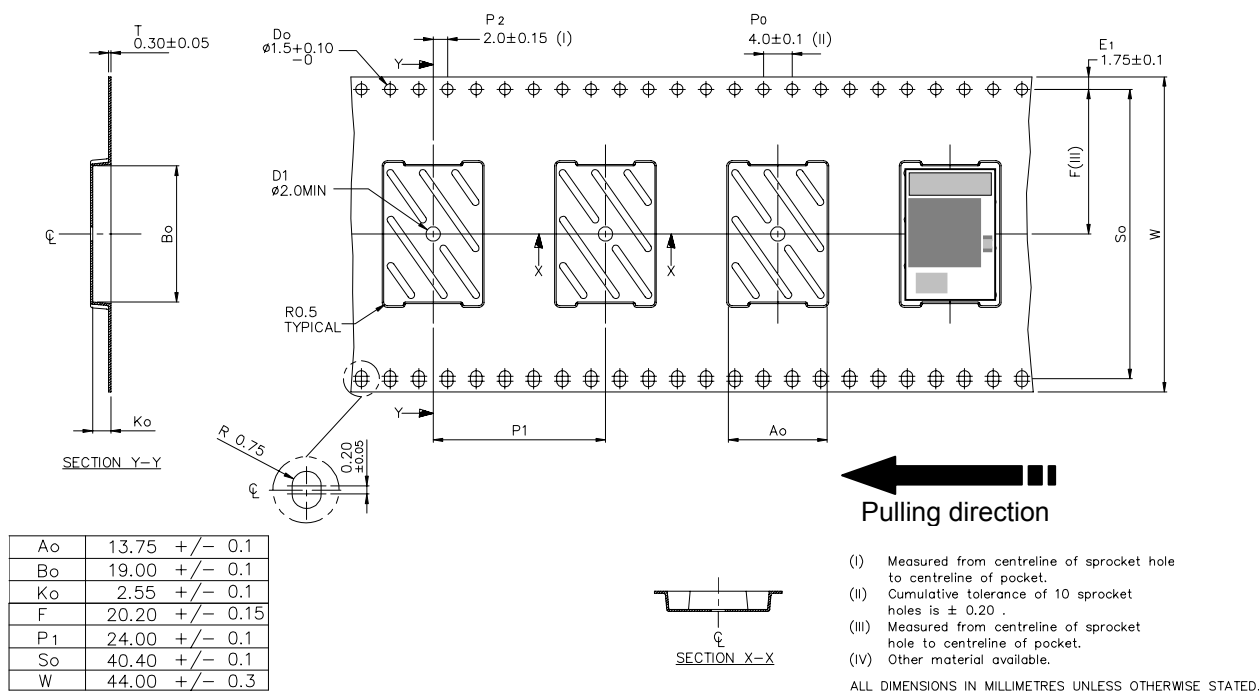

11.2 Reel dimensions

A	330.0 max
B	1.5 min
C	13.0±0.2
D	20.2 min
N	100.0
W1	44.4 +2.0 -0.0
W2	50.4 max

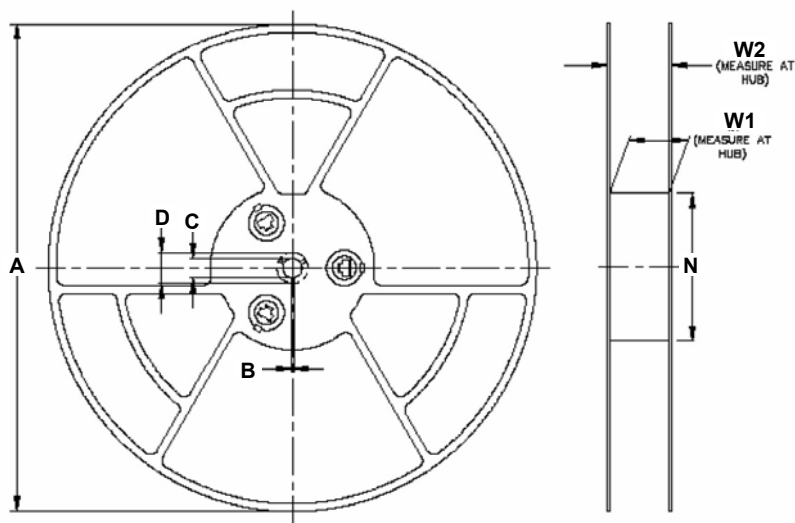



12 Ordering information

The F2M03MLA is available for delivery in volumes.

Part nr:	Description
F2M03MLA-S03	Low power Bluetooth Multimedia module with antenna and Wireless Audio Headset firmware (HSP, HFP, A2DP, AVRCP and SPP)

Please visit our website: www.free2move.net for more information about local distributors and dealers.



13 Document history

Date	Revision	Reason for Change
OCTOBER 2007	c	Minor changes, added new information about Wireless Audio Headset.
JUNE 2007	b	Added information about certification and minor other changes in the document.
JAN 2007	a	Original Publication of this document.

F2M03MLA Datasheet

Datasheet_F2M03MLA_rev_c.pdf

Last revision change
October 2007



14 Acronyms and definitions

Term:	Definition:
Bluetooth	A set of technologies providing audio and data transfer over short-range radio
ACL	Asynchronous Connection-Less. A Bluetooth data packet.
AC	Alternating Current
A-law	Audio encoding standard
API	Application Programming Interface
BCSP	BlueCore™ Serial Protocol
BER	Bit Error Rate. Used to measure the quality of a link
C/I	Carrier Over Interferer
CMOS	Complementary Metal Oxide Semiconductor
CODEC	Coder Decoder
CPU	Central Processing Unit
CQDDR	Channel Quality Driven Data Rate
CTS	Clear to Send
CVSD	Continuous Variable Slope Delta Modulation
DAC	Digital to Analogue Converter
dBm	Decibels relative to 1mW
DC	Direct Current
DFU	Device Firmware Upgrade
GCI	General Circuit Interface. Standard synchronous 2B+D ISDN timing interface
HCI	Host Controller Interface
Host	Application's microcontroller
Host Controller	Bluetooth integrated chip
HV	Header Value
ISDN	Integrated Services Digital Network
ISM	Industrial, Scientific and Medical
ksamples/s	kilosamples per second
L2CAP	Logical Link Control and Adaptation Protocol (protocol layer)
LC	Link Controller
LSB	Least-Significant Bit
p-law	Encoding standard
MISO	Master In Serial Out
OHCI	Open Host Controller Interface
PA	Power Amplifier
PCB	Printed Circuit Board
PCM	Pulse Code Modulation. Refers to digital voice data
PIO	Parallel Input Output
RAM	Random Access Memory
RF	Radio Frequency
RFCOMM	Protocol layer providing serial port emulation over L2CAP
RISC	Reduced Instruction Set Computer
RSSI	Receive Signal Strength Indication
RTS	Ready To Send
RX	Receive or Receiver
SCO	Synchronous Connection-Oriented. Voice oriented Bluetooth packet
SDP	Service Discovery Protocol
SIG	Special Interest Group
SPI	Serial Peripheral Interface
SPP	Serial Port Profile
TBD	To Be Defined
TX	Transmit or Transmitter
UART	Universal Asynchronous Receiver Transmitter
USB	Universal Serial Bus or Upper Side Band (depending on context)
VM	Virtual Machine
www	world wide web



Contact information

For support questions please contact your local dealer

For other purposes use: info@free2move.net

Website: www.free2move.net

Local dealer/distributor



The information given herein includes text, drawings, illustrations and schematics that are believed to be reliable. However, Free2move makes no warranties as to its accuracy or completeness and disclaims any liability in connection with its use. Free2move will in no case be liable for any incidental, indirect or consequential damages arising out of sale, resale, use or misuse of the product. Users of Free2move products should make their own evaluation to determine the suitability of each such product for the specific application.